

DOGE
get inspired

Bathroom
Wellness



DOGE
get inspired

**Bathroom
Wellness**



QUI NASCE OGNI VISIONE. UNO SPAZIO DOVE IL PENSIERO PRENDE FORMA, TRA LUCE, PROPORZIONI E SILENZIO OPERATIVO. OGNI DETTAGLIO RACCONTA UNA CULTURA DEL FARE, DOVE IL DESIGN È UN GESTO QUOTIDIANO, IL PROGETTO UN'ESPRESSIONE DI IDENTITÀ. UN LUOGO DOVE L'ACQUA INCONTRA L'ARTE DEL COSTRUIRE.



HERE EVERY VISION TAKES SHAPE. A SPACE WHERE THOUGHT EVOLVES AMIDST LIGHT, PROPORTIONS, AND FOCUSED SILENCE. EACH DETAIL REFLECTS A CULTURE OF CRAFTSMANSHIP, WHERE DESIGN BECOMES A DAILY GESTURE AND EVERY PROJECT EXPRESSES IDENTITY. A PLACE WHERE WATER MEETS THE ART OF CONSTRUCTION.

HIER ENTSTEHT JEDE VISION. EIN RAUM, IN DEM GEDANKEN FORM ANNEHMEN – ZWISCHEN LICHT, PROPORTIONEN UND KONZENTRIERTER STILLE. JEDES DETAIL ERZÄHLT VON EINER KULTUR DES MACHENS, IN DER DESIGN TÄGLICHE GESTE IST UND DAS PROJEKT AUSDRUCK VON IDENTITÄT WIRD. EIN ORT, AN DEM WASSER AUF DIE KUNST DES BAUENS TRIFFT.

ICI NAÎT CHAQUE VISION. UN ESPACE OÙ LA PENSÉE PREND FORME, ENTRE LUMIÈRE, PROPORTIONS ET SILENCE ACTIF. CHAQUE DÉTAIL RACONTE UNE CULTURE DU SAVOIR-FAIRE, OÙ LE DESIGN DEVIENT GESTE QUOTIDIEN ET LE PROJET EXPRIME UNE IDENTITÉ. UN LIEU OÙ L'EAU RENCONTRE L'ART DE CONSTRUIRE.

GEDA È UN MARCHIO ITALIANO DI RUBINETTERIA PER BAGNO E CUCINA, ACCESSORI BAGNO E SOLUZIONI PER IL WELLNESS. LAVORAZIONI E MATERIALI DI ALTA QUALITÀ, PER PRODOTTI CHE UNISCONO LA FUNZIONALITÀ AD UN DESIGN RICERCATO E ORIGINALE. UN APPROCCIO SARTORIALE CHE SI SVELA NELLA CURA PER IL DETTAGLIO, LE AMPIE POSSIBILITÀ DI PERSONALIZZAZIONE E UNA PARTICOLARE ATTENZIONE PER IL CLIENTE E LE SUE NECESSITÀ. OGNI PROGETTO, UNA NUOVA ISPIRAZIONE.

GEDA IS AN ITALIAN BRAND OF BATHROOM AND KITCHEN FAUCETS, BATHROOM ACCESSORIES AND WELLNESS SOLUTIONS. HIGH QUALITY WORKMANSHIP AND MATERIALS, FOR PRODUCTS THAT COMBINE FUNCTIONALITY WITH A REFINED AND ORIGINAL DESIGN. A SARTORIAL APPROACH THAT IS REVEALED IN THE ATTENTION TO DETAIL, THE WIDE POSSIBILITIES OF CUSTOMIZATION AND A SPECIAL ATTENTION TO THE CUSTOMER AND HIS NEEDS. EVERY PROJECT, A NEW INSPIRATION.

GEDA IST EINE ITALIENISCHE MARKE VON ARMATUREN FÜR BAD UND KÜCHE, BADZUBEHÖR UND WELLNESS-LÖSUNGEN. HOCHWERTIGE BEARBEITUNGEN UND MATERIALIEN, FÜR PRODUKTE, DIE DIE ZWECKMÄSSIGKEIT UND AUSGESUCHTES UND ORIGINELLES DESIGN MITEINANDER VEREINEN. EINE MASSGESCHNEIDERTE LÖSUNG, DIE SICH IN DEN AUSGESUCHTEN DETAILS, DEN INDIVIDUELLEN GESTALTUNGSMÖGLICHKEITEN SOWIE IN EINER BESONDEREN ACHTUNG FÜR DIE KUNDENBEDÜRFNISSE AUSDRÜCKT. JEDES PROJEKT, EINE NEUE INSPIRATION.

GEDA EST UNE MARQUE ITALIENNE DE ROBINETTERIE POUR SALLE DE BAINS ET CUISINE, D'ACCESSOIRES POUR SALLE DE BAINS ET DE SOLUTIONS DE WELLNESS. DES FAÇONNAGES ET DES MATÉRIAUX DE GRANDE QUALITÉ, POUR DES PRODUITS QUI CONJUGENT LA FONCTIONNALITÉ À UN DESIGN RECHERCHÉ ET ORIGINAL. UNE APPROCHE ARTISANALE QUI SE DEVINE DANS LE SOUCI DU DÉTAIL, LES NOMBREUSES OPTIONS DE PERSONNALISATIONS ET UNE ATTENTION PARTICULIÈRE POUR LE CLIENT ET SES BESOINS. UNE NOUVELLE INSPIRATION À CHAQUE PROJET.

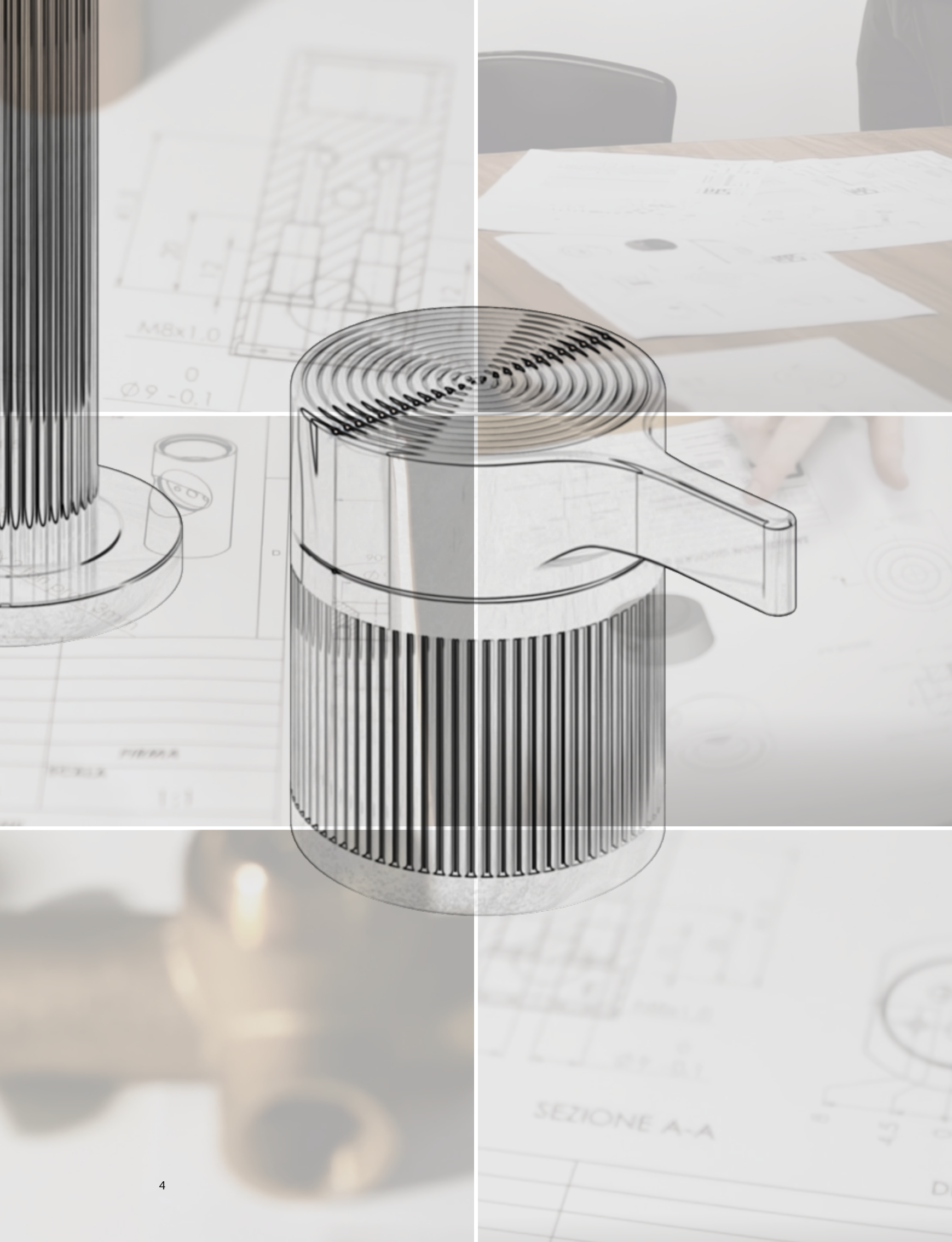

DOGE NASCE DALLA SINTESI TRA GRAZIA VENEZIANA E RIGORE CONTEMPORANEO. LINEE NEO-DÉCO E SUPERFICI CANNETTATE DEFINISCONO VOLUMI PURI, CAPACI DI ESALTARE LA LUCE E SCANDIRE LO SPAZIO CON ELEGANTE PRECISIONE. LA RUBINETTERIA DIVENTA PRESENZA ARCHITETTONICA E SENSORIALE, CONCEPITA PER DIALOGARE CON AMBIENTI DAL CARATTERE DISTINTIVO, EVOCANDO UNA RITUALITÀ SILENZIOSA E RAFFINATA.

DOGE EMERGES FROM THE FUSION OF VENETIAN GRACE AND CONTEMPORARY RIGOR. NEO-DÉCO LINES AND FLUTED SURFACES CREATE PURE VOLUMES, ENHANCING THE LIGHT AND DEFINING THE SPACE WITH ELEGANT PRECISION. THE TAPWARE BECOMES AN ARCHITECTURAL AND SENSORY PRESENCE, THOUGHTFULLY DESIGNED TO ENGAGE WITH DISTINCTIVE ENVIRONMENTS, EVOKING A SILENT, REFINED RITUAL.

DOGE ENTSTEHT AUS DER VERBINDUNG VENEZIANISCHER ANMUT MIT ZEITGENÖSSISCHER KLARHEIT. NEO-DÉCO-LINIEN UND GERIFFELTE OBERFLÄCHEN FORMEN KLARE VOLUMEN, DIE LICHT WIRKUNGSVOLL EINFANGEN UND RÄUME MIT ELEGANTER PRÄZISION DEFINIEREN. DIE ARMATUREN WERDEN ZUR ARCHITEKTONISCHEN UND SINNLICHEN PRÄSENZ, DIE IM DIALOG MIT CHARAKTERVOLLEN RÄUMEN EINE STILLE, RAFFINIERTER RITUALITÄT ERZEUGEN.

DOGE NAÎT DE LA RENCONTRE ENTRE LA GRÂCE VÉNITIENNE ET LA RIGUEUR CONTEMPORAINE. LES LIGNES NÉO-DÉCO ET LES SURFACES CANNELÉES DESSINENT DES VOLUMES PURS, METTANT EN VALEUR LA LUMIÈRE ET STRUCTURANT L'ESPACE AVEC ÉLÉGANCE ET PRÉCISION. LA ROBINETTERIE DEVIENT UNE PRÉSENCE ARCHITECTURALE ET SENSORIELLE, CONÇUE POUR DIALOGUER AVEC DES ESPACES AU CARACTÈRE DISTINCTIF, ÉVOQUANT UN RITUEL SILENCIEUX ET RAFFINÉ.

VIVIAMO IN UN'EPOCA IN CUI L'IMPEGNO PER LA SOSTENIBILITÀ È ESSENZIALE PER PRESERVARE IL FUTURO DEL NOSTRO PIANETA. OGNI AZIONE CONTA. SOLO ADOTTANDO UNO STILE DI VITA RESPONSABILE POSSIAMO CONTRIBUIRE ALLA COSTRUZIONE DI UN MONDO PIÙ SOSTENIBILE. LIMITARE GLI SPRECHI, RICICLARE I MATERIALI, PROMUOVERE L'UTILIZZO DI ENERGIA PULITA E SICURA SONO I PRIMI FONDAMENTALI PASSI PER RIDURRE IL NOSTRO IMPATTO.

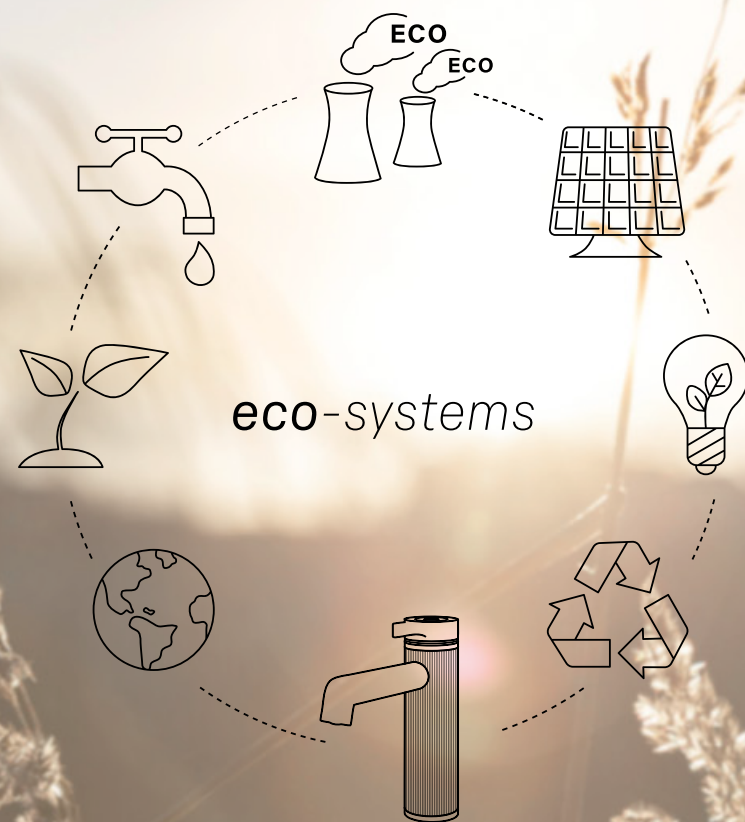

WE LIVE IN A TIME WHEN COMMITMENT TO SUSTAINABILITY IS ESSENTIAL TO PRESERVING THE FUTURE OF OUR PLANET. EVERY ACTION COUNTS. ONLY BY ADOPTING A RESPONSIBLE LIFESTYLE CAN WE HELP BUILD A MORE SUSTAINABLE WORLD. LIMITING WASTE, RECYCLING MATERIALS, AND PROMOTING THE USE OF CLEAN AND SAFE ENERGY ARE THE FIRST FUNDAMENTAL STEPS TO REDUCING OUR IMPACT.

WIR LEBEN IN EINER EPOCHE, IN DER DER EINSATZ FÜR DIE NACHHALTIGKEIT VON ENTSCHEIDENDER BEDEUTUNG FÜR DIE ZUKUNFT UNSERES PLANETEN IST. JEDE HANDLUNG ZÄHLT. NUR DURCH ANWENDUNG EINES VERANTWORTUNGSBEWUSSTEN LEBENSSTILS KÖNNEN WIR EINE NACHHALTIGERE WELT GEWÄHRLEISTEN. DIE RESSOURCENVERSCHWENDUNG EINSCHRÄNKEN, DIE MATERIALIEN NEU VERWERTEN, DEN EINSATZ VON SAUBERER ENERGIE FÖRDERN, DIESE SIND DIE ERSTEN ENTSCHEIDENDEN SCHRITTE FÜR DIE REDUZIERUNG UNSERER UMWELTBELASTUNG.

NOUS VIVONS DANS UNE ÉPOQUE OÙ L'ENGAGEMENT POUR LA DURABILITÉ EST ESSENTIEL POUR PRÉSERVER LE FUTUR DE NOTRE PLANÈTE. CHAQUE ACTION COMPTE. CE N'EST QU'EN ADOPTANT UN STYLE DE VIE RESPONSABLE QUE NOUS POUVONS CONTRIBUER À LA CONSTRUCTION D'UN MONDE PLUS DURABLE. LIMITER LES GASPILLAGES, RECYCLER LES MATÉRIAUX, PROMOUVOIR L'UTILISATION DE L'ÉNERGIE PROPRE ET SÛRE CONSTITUENT LES PREMIÈRES ÉTAPES FONDAMENTALES POUR RÉDUIRE NOTRE IMPACT.

CERTIFICAZIONI E ECOSOSTENIBILITÀ

CERTIFICATIONS AND ECO-SUSTAINABILITY

La nostra lavorazione aziendale è certificata dal sistema di qualità ISO 9001 e dal sistema ambientale ISO 14001, entrambi certificati da DNV GL.

Our business processes are certified by the ISO 9001 quality system and ISO 14001 environmental system, both certified by DNV GL.



GEDA si dedica con impegno alla promozione e sensibilizzazione del risparmio energetico e del consumo consapevole delle risorse. Ciò viene realizzato attraverso una produzione attenta e rigorosa, volta a garantire non solo la tutela dell'ambiente, ma anche la salvaguardia della salute delle persone, eliminando condizioni di lavoro o processi potenzialmente dannosi.

GEDA is dedicated to promoting and raising awareness of energy conservation and conscious consumption of resources. This is accomplished through careful and rigorous production, aimed at ensuring not only the protection of the environment, but also the protection of people's health by eliminating potentially harmful working conditions or processes.



ZERTIFIZIERUNGEN UND UMWELTVERTRÄGLICHKEIT

CERTIFICATIONS ET ÉCODURABILITÉ

Unsere Arbeitsweise im Betrieb ist durch das Qualitätssystem ISO 9001 sowie vom Umweltsystem ISO 14001 zertifiziert, beide mit Zertifikat DNV GL.

Notre travail est certifié par le système de qualité ISO 9001 et le système environnemental ISO 14001, tous deux certifiés par DNV GL.

GEDA widmet sich mit Leidenschaft der Förderung und Sensibilisierung der Energieeinsparnis und dem bewussten Konsum der Ressourcen. Dies erfolgt durch eine genaue und strenge Produktion, nicht nur mit dem Ziel des Umweltschutzes, sondern auch der Wahrung der Gesundheit der Menschen, indem Arbeitsbedingungen oder Prozesse beseitigt werden, die womöglich einen Schaden darstellen.

GEDA s'engage à promouvoir et à sensibiliser à l'économie d'énergie et à la consommation consciente des ressources par le biais d'une production soignée et rigoureuse, qui garantit non seulement la protection de l'environnement, mais aussi la santé des personnes, en éliminant les conditions de travail ou les processus potentiellement dangereux.

UN'ALLURE DÉCO SI FONDE CON LA SOLENNITÀ VENEZIANA, TRA GEOMETRIE RITMATE E CHIAROSCURI D'ACQUA. DOGE È UN SISTEMA ARCHITETTONICO DI SEGNI ELEGANTI E PROPORZIONI PREZIOSE.



A DÉCO, ALLURE BLENDS WITH VENETIAN SOLEMNITY THROUGH RHYTHMIC GEOMETRIES AND AQUATIC CHIAROSCURO. DOGE IS AN ARCHITECTURAL SYSTEM OF REFINED SIGNS AND PRECIOUS PROPORTIONS.

EINE DÉCO-ALLURE VERSCHMILZT MIT VENEZIANISCHER FEIERLICHKEIT ZWISCHEN RHYTHMISCHEN GEOMETRIEN UND DEM CHIAROSCURO DES WASSERS. DOGE IST EIN ARCHITEKTONISCHES SYSTEM ELEGANTER ZEICHEN UND WERTVOLLER PROPORTIONEN.

UNE ALLURE DÉCO S'ALLIE À LA SOLENNITÉ VENITIENNE ENTRE GÉOMÉTRIES RYTHMÉES ET CLAIRS-OBSCURS AQUATIQUES. DOGE EST UN SYSTÈME ARCHITECTURAL DE SIGNES ÉLÉGANTS ET DE PROPORTIONS PRÉCIEUSES.



DOGE
bathroom collection





DGE13
Rubinetto 3 fori top.
Finitura Oro Satinato.

_3-hole deck-mounted basin tap.
Satin Gold finishing.
_3-Loch-Waschtischmischerset.
Oberflächen Gold Satiniert.
_Melangeur de lavabo 3 trous sur plan.
Finition Or Satin.



**DGE1**

Miscelatore lavabo.
Finitura Canna di Fucile.

_Basin mixer.
Gunmetal finishing.
_Waschtischmischer.
Oberflächen Gun Powder.
_Mitigeur lavabo.
Finition Gunmetal.

DGE3

Miscelatore lavabo rialzato.
Finitura Ottone Satinato.

_High basin mixer.
Satin Brass finishing.
_High Rise Waschtischmischer.
Oberflächen Messing Satiniert.
_Mitigeur lavabo haut.
Finition Laiton Satin.

DGE84

Miscelatore lavabo 2 fori a parete.
Finitura Tortora Light.

_2-hole wall-mounted basin mixer.
Light Dove finishing.
_2-Loch Wandmischer.
Oberflächen Matt Taubengrau.
_Mitigeur mural 2 trous.
Finition Tourterelle Light.





DGE3
Miscelatore lavabo rialzato.
Finitura Ottone Satinato.

- _ High basin mixer.
Satin Brass finishing.
- _ High Rise Waschtischmischer.
Oberflächen Messing Satiniert.
- _ Mitigeur lavabo haut.
Finition Laiton Satin.

GGE52 + FLEX + DOC11
Kit vasca orizzontale.
Finitura Rame Opaco PVD.

- _ Horizontal Bath Group.
Matt Copper PVD finishing.
- _ Wannenthermostat horizontal.
Oberflächen Matt Kupfer PVD.
- _ Mitigeur mural baignoire thermostatique.
Finition Cuivre Mat PVD.



DGE84
Miscelatore lavabo 2 fori a parete.
Finitura Roseè Lucido PVD.

- _ 2-hole wall-mounted basin mixer.
Polished Roseè PVD finishing.
- _ 2-Loch Wandmischer.
Oberflächen Roseè Poliert PVD.
- _ Mitigeur mural 2 trous.
Finition Roseè Poli PVD.

DGE57
Rubinetto lavabo incasso 3 fori.
Finitura PVD Antracite Opaco.

- _ 3-hole built-in basin tap.
Matt Anthracite PVD finishing.
- _ 3-Loch Waschtischarmatur.
Oberflächen Matt Anthrazit PVD.
- _ Melangeur de lavabo 3 trous.
Finition Anthracite Mat PVD.





PVG1
 Piantana vasca a pavimento.
 Finitura Carbon Lucido PVD.

- _ Free-standing bath mixer.
 Polished Carbon PVD finishing.
- _ Wannenarmatur.
 Oberflächen Carbon Poliert PVD.
- _ Mitigeur baignoire au sol.
 Finition Carbon Poli PVD.

EDG3
 Doccia incasso meccanico 3 vie.
 Finitura Tortora Light.

- _ Manual shower mixer with 3-way
 diverter. Light Dove finishing.
- _ Unterputz-Brausemischer mit 3-Wege-
 Ventil. Oberflächen Matt Taubengrau.
- _ Mitigeur douche mural mécanique 3
 voies. Finition Tourterelle Light.



Finiture disponibili

_Available finishes _Erhältliche Oberflächen _Finitions disponibles



Cromo

Chrome
Chrom
Chrome



Canna di Fucile

Gunmetal
Gun Powder
Gunmetal



Oro Satinato

Satin Gold
Gold Satiniert
Or Satin



Rame Satinato

Satin Copper
Kupfer Satiniert
Cuivre Satin



Ottone Satinato

Satin Brass
Messing Satiniert
Laiton Satin



Bianco Opaco

Matt White
Mattweiss
Blanc mat



Tortora Light

Light Dove
Taubengrau
Tourterelle light



Medium Grey

Medium Grey
Basaltgrau
Medium gris



Green Grey

Green Grey
Graugrün
Vert gris



Blue Grey

Blue Grey
Graublau
Bleu gris



Nero Opaco

Matt Black
Mattschwarz
Noir mat



PVD Carbon lucido

Polished Carbon
Carbon Poliert
Carbon Poli



PVD Roseè lucido

Polished Roseè
Roseè Poliert
Roseè Poli



PVD Oro lucido

Polished Gold
Gold Poliert
Or Poli



PVD Antracite opaco

Matt Anthracite
Matt Anthrazit
Anthracite Mat



PVD Rame opaco

Matt Copper
Matt Kupfer
Cuivre Mat



PVD Oro opaco

Matt Gold
Matt Gold
Or Mat



DOGE



DGE1
Miscelatore lavabo.
Basin mixer.
Waschtischmischer.
Mitigeur lavabo.



DGE3
Miscelatore lavabo rialzato.
High basin mixer.
High Rise Waschtischmischer.
Mitigeur lavabo haut.



DGE4
Miscelatore bidet.
Bidet mixer.
Bidetmischer.
Mitigeur bidet.



DGE38
Miscelatore doccia incasso meccanico.
Manual built-in shower mixer.
Unterputz-Brausemischer.
Mitigeur monocommande mural.



EDG2
Doccia incasso meccanico 2 vie.
Manual shower mixer with 2-way diverter.
Unterputz-Brausemischer mit 2-Wege-Ventil.
Mitigeur douche mural mécanique 2 voies.



EDG3
Doccia incasso meccanico 3 vie.
Manual shower mixer with 3-way diverter.
Unterputz-Brausemischer mit 3-Wege-Ventil.
Mitigeur douche mural mécanique 3 voies.



CTD1
Bocca lavabo top.
Deck-mounted basin spout.
Waschtisch-Auslauf.
Bec vasque sur plan.



DGE13
Rubinetto 3 fori top.
3-hole deck-mounted basin tap.
3-Loch-Waschtischmischer.
Melangeur de lavabo 3 trous sur plan.



DGE25
Miscelatore monocomando top.
Deck-mounted mixer.
Einhebelmischer zur Standmontage.
Mitigeur monocommande sur plan.



GGE51
Kit doccia orizzontale.
Horizontal shower Group.
Brausethermostat horizontal.
Brausethermostat horizontal.



CMD1
Bocca lavabo a muro.
Wall-mounted basin spout.
Waschtischauslauf zur Wandmontage.
Bec vasque mural.



DGE84
Mix lavabo 2 fori a parete canna corta.
2-hole wall-mounted mixer short spout.
2-Loch Wandmischer, kurzer Auslauf.
Mitigeur mural 2 trous bec court.



DGE57
Rub. lavabo 3 fori a parete canna corta.
3-hole wall-mounted tap short spout.
3-Loch Wandmischer, kurzer Auslauf.
Mélangeur mural 3 trous bec court.



GGE52
Kit vasca orizzontale.
Horizontal Bath Group.
Wannethermostat horizontal.
Mitigeur mural baignoire thermostatique.



GGE43
Termostatico con collettore 4 vie.
Thermostatic mixer with 4 ways manifold.
Brausethermostat mit 4-Wege-Umstellventil.
Mitigeur thermostatique avec collecteur 4 voies.



PVG1
Piantana vasca a pavimento.
Free-standing bath mixer.
Wannenarmatur.
Mitigeur baignoire au sol.

LA COLLEZIONE DI RUBINETTERIA DOGE SI COMPLETA CON LE SOLUZIONI WELLNESS E UNA RICCA SCELTA DI ACCESSORI. PER UN AMBIENTE BAGNO DI PRESTIGIO IN OGNI DETTAGLIO.

THE DOGE TAPWARE COLLECTION IS COMPLEMENTED BY WELLNESS SOLUTIONS AND A RICH SELECTION OF ACCESSORIES, FOR A PRESTIGIOUS BATHROOM AMBIENCE IN EVERY DETAIL.

DIE DOGE-ARMATURENKOLLEKTION WIRD DURCH WELLNESSLÖSUNGEN UND EINE GROÖE AUSWAHL AN ACCESSOIRES ERGÄNZT. FÜR EIN HOCHWERTIGES BADEZIMMERAMBIENTE IN JEDEM DETAIL.

LA COLLECTION DE RUBINETTERIE DOGE EST COMPLÉTÉE PAR DES SOLUTIONS BIEN-ÊTRE ET UN LARGE CHOIX D'ACCESSOIRES. POUR UNE SALLE DE BAIN PRESTIGIEUSE DANS LES MOINDRES DÉTAILS.



DOGE
wellness & accessories

SWD3G

Soffione UP22 con 7 ugelli soft-flow.
Finitura Carbon Lucido PVD + Nero Opaco.

_ UP22 shower head with 7 soft-flow nozzles.
Polished Carbon PVD + Matt Black finishing.
_ UP22 Duschkopf mit 7 Soft-Flow-Düsen.
Oberflächen Carbon Poliert PVD + Schwarz.
_ UP22 douche de tête avec 7 buses à débit
douce. Finition Carbon Poli PVD + Noir Mat.





SDE30
Soffione Ø30 cm.
Finitira Oro Opaco PVD + scocca
Oro Satinato.

- _ Ø30 cm shower head.
Polished Gold PVD + Satin Gold
shell finishing.
- _ Duschkopf Ø30 cm. Oberflächen
Gold Poliert PVD + Gold Satiniert
Gehäuseausführung.
- _ Douche de tête Ø30 cm.
Finition Or Poli PVD + boîtier
Or Satin.



SDE20
Soffione Ø20 cm.
Finitura Blue Grey.

_ Ø20 cm shower head.
Blue Grey finishing.
_ Duschkopf Ø20 cm.
Oberflächen Graublau.
_ Douche de tête Ø20 cm.
Finition Bleu Gris.

SDE25
Soffione Ø25 cm.
Finitura Oro Satinato.

_ Ø25 cm shower head.
Satin Gold finishing.
_ Duschkopf Ø25 cm.
Oberflächen Gold Satiniert.
_ Douche de tête Ø25 cm.
Finition Or Satin.

SDE30
Soffione Ø30 cm.
Finitura Rame Satinato.

_ Ø30 cm shower head.
Satin Copper finishing.
_ Duschkopf Ø30 cm.
Oberflächen Kupfer Satiniert.
_ Douche de tête Ø30 cm.
Finition Cuivre Satin.





PIA30

Piastra Ø57 cm con cromoterapia.
Finitura piastra Cromo + scocca
Rame Satinato.

- _ Ø57 cm ceiling shower head.
Chrome plate + Satin Copper shell
finishing.
- _ Deckenplatte Ø57 cm.
Oberflächen Chrom platte + Kupfer
Satinert Gehäuseausführung
- _ Ciel de pluie Ø57 cm.
Finition plaque Chrome + boîtier
Cuivre Satin.

SWD1G
Soffione UP22 con 7 ugelli soft-flow.
Finitura Oro Satinato + Nero Opaco.

_ UP22 shower head with 7 soft-flow nozzles.
Satin Gold + Matt Black finishing.
_ UP22 Duschkopf mit 7 Soft-Flow-Düsen.
Oberflächen Gold Satiniert + Schwarz.
_ UP22 douche de tête avec 7 buses à débit
douce. Finition Or Satin + Noir Mat.

SWD5G
Soffione UP22 con 3 aeratori funzione
nebulizzazione.
Finitura Oro Satinato + Nero Opaco.

_ UP22 shower head with 3 nebulizing
aerators. Satin Gold + Matt Black finishing.
_ UP22 Duschkopf mit 3 Lüftern
Zerstäuberfunktion. Oberflächen Gold
Satiniert + Schwarz.
_ UP22 douche de tête avec 3 aérateurs
fonction nébulisation. Finition Or Satin + Noir Mat.





SDE20
Soffione Ø20 cm ispezionabile.
Ø20 cm inspectable shower head.
Kopfbrause Ø20 cm, mit Wartungszugang.
Pommeau de douche inspectable Ø20 cm.

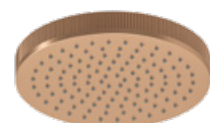

SDE25
Soffione Ø25 cm ispezionabile.
Ø25 cm inspectable shower head.
Kopfbrause Ø25 cm, mit Wartungszugang.
Pommeau de douche inspectable Ø25 cm.

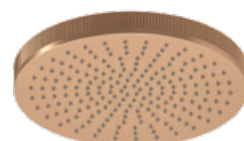

SDE30
Soffione Ø30 cm ispezionabile.
Ø30 cm inspectable shower head.
Kopfbrause Ø30 cm, mit Wartungszugang.
Pommeau de douche inspectable Ø30 cm.

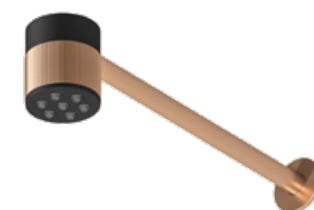

SWD1G
Soffione UP22 con 7 ugelli soft-flow e braccio a parete.
UP22 shower head with 7 soft-flow nozzles and shower arm.
UP22 Duschkopf mit 7 Soft-Flow-Düsen und Wandarm.
UP22 douche de tête avec 7 buses à débit douce et bras mural.

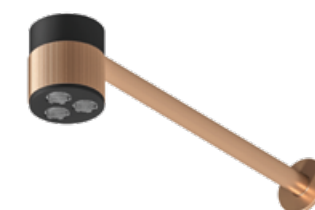

SWD2G
Soffione UP22 con 3 aeratori funzione pioggia e braccio a parete.
UP22 shower head with 3 aerators with rain function and shower arm.
UP22 Duschkopf mit 3 Lüftern Regenfunktion und Wandarm.
UP22 douche de tête avec 3 aérateurs avec fonction pluie et bras mural.

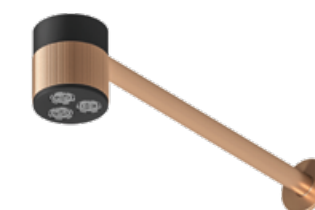

SWD5G
Soffione UP22 con 3 aeratori nebulizzatori e braccio a parete.
UP22 shower head with 3 nebulizer aerators and shower arm.
UP22 Duschkopf mit 3 Lüftern Zerstäuberfunktion und Wandarm.
UP22 douche de tête avec 3 aérateurs fonction nébulisation et bras mural.

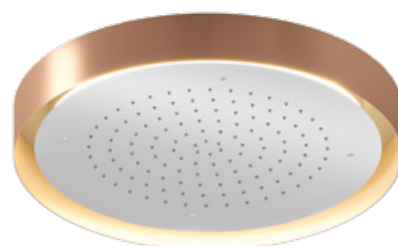

PIA30G
Piastra a soffitto ø57 cm con cromoterapia perimetrale.
Ø57 cm ceiling shower head with perimetral chromotherapy.
Deckenplatte Ø57 cm mit perimetrale chromotherapie.
Ciel de pluie Ø57 cm avec chromothérapie périmétrique.



K6
Kit presa acqua, flessibile e doccia.
Kit with water connection, flexible hose and hand shower.
Wasseranschluss mit Halterung, brause und Brauseslauch.
Kit de raccordement d'eau, tuyau flexible et douchette.



SWD3G
Soffione UP22 con 7 ugelli soft-flow e snodo a parete.
UP22 shower head with 7 soft-flow nozzles and swivel joint.
UP22 Duschkopf mit 7 Soft-Flow-Düsen und Wandgelenk.
UP22 douche de tête avec 7 buses à débit douce et raccordement avec joint.



SWD4G
Soffione UP22 con 3 aeratori funzione pioggia e snodo a parete.
UP22 shower head with 3 aerators with rain function and swivel joint.
UP22 Duschkopf mit 3 Lüftern Regenfunktion und Wandgelenk.
UP22 douche de tête avec 3 aérateurs avec fonction pluie et raccordement avec joint.



SWD6G
Soffione UP22 con 3 aeratori nebulizzatori e snodo a parete.
UP22 shower head with 3 nebulizer aerators and swivel joint.
UP22 Duschkopf mit 3 Lüftern Zerstäuberfunktion und Wandgelenk.
UP22 douche de tête avec 3 aérateurs fonction nébulisation et raccordement avec joint.



ARM6
Braccio doccia a soffitto.
Ceiling shower arm.
Deckenduscharm rund.
Bras de douche pour montage au plafond.



ARM7
Braccio doccia a parete.
Wall-mounted shower arm.
Wandduscharm rund.
Bras de douche mural.



BJM3
Bodyjet fisso.
Fixed bodyjet.
Bodyjet fest.
Bodyjet fixe.



BJM5
Bodyjet direzionabile.
Adjustable bodyjet.
Bodyjet drehbar.
Bodyjet directionnel.



BNT1
Nebulizzatore fisso.
Fixed nebulizer.
Fester Seitennebelbrausen.
Nébuliseur fixe.



ADP2
Porta rotolo.
Finitura Roseè Lucido PVD.

_ Toilet roll holder.
Polished Roseè PVD finishing.
_ Toilettenpapierhalter.
Oberflächen Roseè Poliert PVD.
_ Porte-rouleau de papier.
Finition Roseè Poli PVD.





ADB1 + ABD1
 Dispenser sapone e bicchiere Ø70.
 Finitura Canna di Fucile.

_ Soap dispenser and Tumbler Ø70.
 Gunmetal finishing.
 _ Seifenspender und Zahnputzbecher Ø70.
 Oberflächen Gun Powder.
 _ Distributeur de savon et Gobelet brosse à
 dents Ø70. Finition Gunmetal.



ADP1 + ADP2 + ACD4 + APD1
 Porta salviette, appendino, porta rotolo e piantana.
 Finitura Ottone Satinato.

_ Towel rail, robe hook, roll holder and free-standing roll
 and brush holder. Satin Brass finishing.
 _ Handtuchhalter, Kleiderhaken, Toilettenpapierhalter
 und Freistehender Papier und Bürstenhalter.
 Oberflächen Messing Satiniert.
 _ Porte-serviettes, cintre, porte-rouleau et porte-rouleau
 au sol avec brosse. Finition Laiton Satin.



ADP1
Appendino.
Robe hook.
Kleiderhaken.
Cintre.

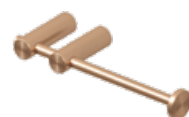

ADP2
Porta rotolo.
Toilet roll holder.
Toilettenpapierhalter.
Porte-rouleau de papier toilette.

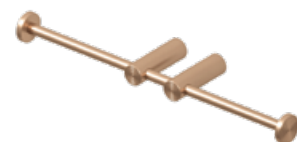

ADP10
Porta rotolo doppio.
Double toilet roll holder.
Doppelter Toilettenpapierhalter.
Porte-rouleau de papier toilette double.



ADP3
Porta salviette 300 mm.
Towel rail 300 mm.
Handtuchhalter 300 mm.
Porte-serviettes 300 mm.



ACD4
Porta salviette 450 mm.
Towel rail 450 mm.
Handtuchhalter 450 mm.
Porte-serviettes 450 mm.



ACD5
Porta salviette 600 mm.
Towel rail 600 mm.
Handtuchhalter 600 mm.
Porte-serviettes 600 mm.



ADB1
Dispenser sapone Ø70 mm.
Soap dispenser Ø70 mm.
Seifenspender Ø70 mm.
Distributeur de savon Ø70 mm.



ADB2
Dispenser sapone medio Ø70 mm.
Medium soap dispenser Ø70 mm.
Seifenspender mittel Ø70 mm.
Distributeur de savon moyen Ø70 mm.



ABD1
Bicchiere Ø70 mm.
Tumbler Ø70 mm.
Zahnputzbecher Ø70 mm.
Gobelet à brosse à dents Ø70 mm.

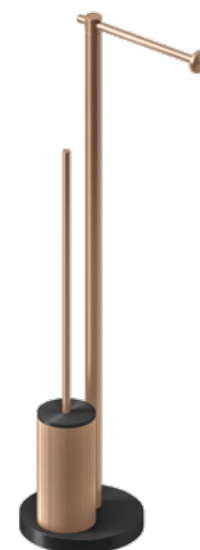

APD1
Piantana porta rotolo e scopino basso.
Free-standing toilet roll and low brush holder.
Round freistehender Toilettenpapierhalter mit Toilettenbürstenhalter.
Porte-rouleau de papier toilette avec brosse pour toilette basse.

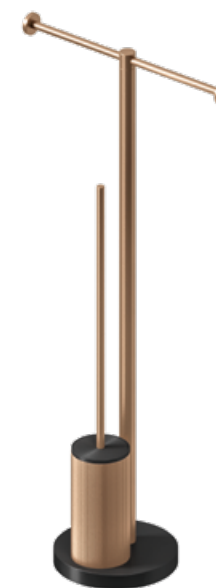

APD2
Piantana con doppio porta rotolo e scopino basso.
Free-standing double toilet roll and low brush holder.
Round freistehender doppelter Toilettenpapierhalter mit Toilettenbürstenhalter.
Porte-rouleau de papier toilette double avec brosse pour toilette basse.



APD3
Piantana porta rotolo e scopino medio.
Free-standing toilet roll and medium brush holder.
Round freistehender Toilettenpapierhalter mit Toilettenbürstenhalter.
Porte-rouleau de papier toilette avec brosse pour toilette moyenne.



APD4
Piantana con doppio porta rotolo e scopino medio.
Free-standing double toilet roll and low brush holder.
Round freistehender doppelter Toilettenpapierhalter mit Toilettenbürstenhalter.
Porte-rouleau de papier toilette double avec brosse pour toilette moyenne.



ASD2
Scopino Ø70 mm.
Low toilet brush Ø70 mm.
Toilettenbürste Ø70 mm.
Brosse de toilettes Ø70 mm.



ASD4
Scopino medio Ø70 mm.
Medium toilet brush Ø70 mm.
Toilettenbürste mittel Ø70 mm.
Brosse de toilettes moyenne Ø70 mm.



ASD1
Scopino rialzato Ø70 mm.
High toilet brush Ø70 mm.
Toilettenbürste hoch Ø70 mm.
Brosse de toilettes haute Ø70 mm.

Geda Srl si riserva in qualunque momento di apportare, senza preavviso, modifiche mirate al miglioramento funzionale e qualitativo dei propri prodotti o di sopprimerne la produzione. Dati, misure o schemi su questo catalogo hanno solamente carattere informativo e non sono vincolanti.

I colori rappresentati sono da considerarsi solamente indicativi.

Geda Srl reserves the right at any time, without prior notice, to make changes aimed at improving the functionality and quality of its products or to discontinue production. Data, measurements or technical drawings in this catalogue are for information purposes only and are not binding.

The colours shown are to be considered as indicative only.

Geda Srl behält sich das Recht vor, jederzeit und ohne Vorankündigung Änderungen vorzunehmen, um die Funktionalität und Qualität der Produkte zu verbessern, oder die Produkte aus dem aktiven Sortiment zu nehmen. Die in diesem Katalog enthaltenen Daten, Maße oder Diagramme dienen nur zu Informationszwecken und sind nicht verbindlich.

Die dargestellten Farben sind nur als Richtwerte zu betrachten.

Geda Srl se réserve le droit, à tout moment et sans préavis, d'apporter des modifications visant à améliorer la fonctionnalité et la qualité de ses produits ou d'en arrêter la production. Les données, mesures ou schémas figurant dans ce catalogue sont donnés à titre informatif et ne sont pas contractuels.

Les couleurs représentées ne doivent être considérées qu'à titre indicatif.

