

SEVENTY SHOWER MIXER WITH BOX

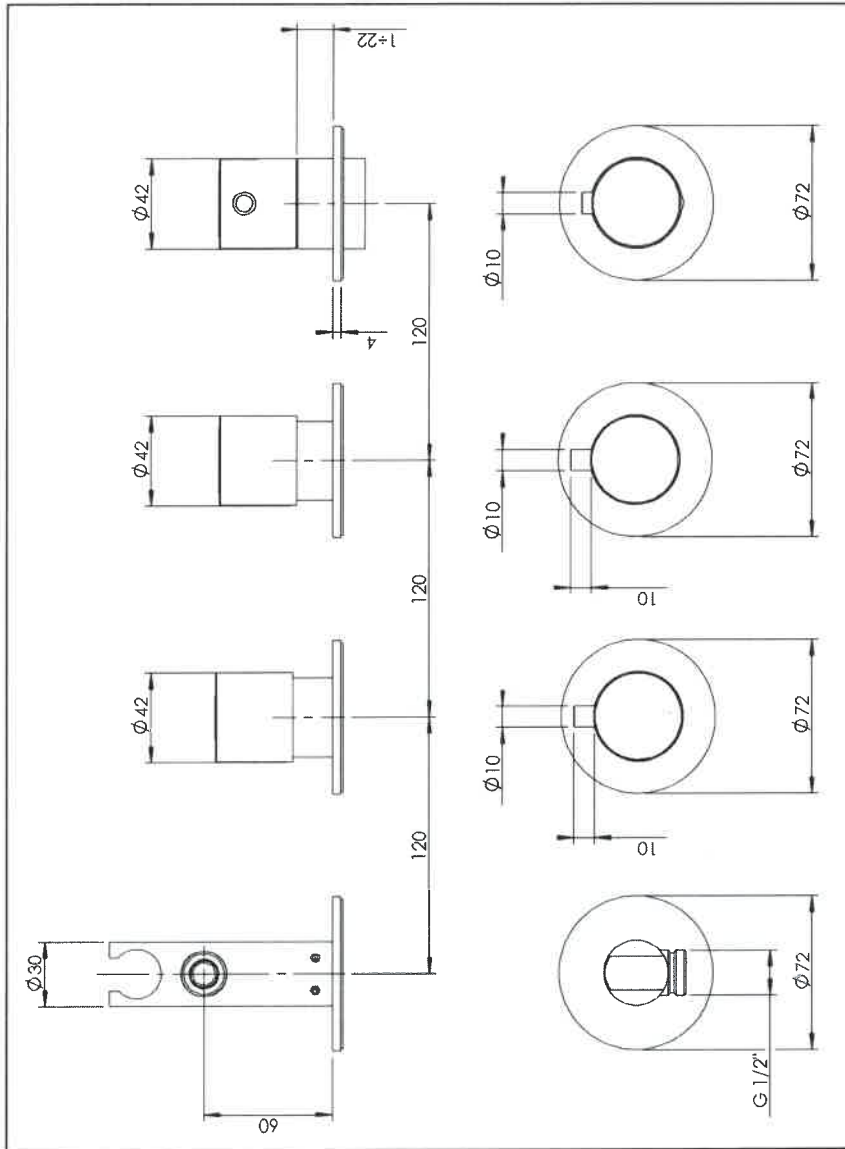

GENERAL FEATURES

This mixer is suitable for all water heating systems provided it is installed correctly by a competent and qualified installer.

OPERATING SPECIFICATIONS

Hot water supply temperature:

Maximum: 85°C

Advisable: 65°C

Minimum: 5°C

Minimum difference between hot and mixed temperature 10°C

The temperature of the inlet hot water must be higher than the maximum mixed water temperature required from the outlet.

Working pressures

Maximum: 10 bar

Advisable: 3 bar

Minimum: 0,1 bar

Hot and cold operating pressures should be kept as balanced as possible in order to maintain maximum efficiency.

When the supply pressure is higher than 5 bar a pressure reducing valve should be fitted before the shower mixer.

TECHNICAL DATA

The mixer is supplied with a cover plate for the installation at a depth from 70 mm to 90.5 mm. The temperature control knob is pre-set from the manufacturer at 38°C.

The mixer ports are supplied with a female thread G 3/4", NPT 3/4".

The thermostatic mixer controls and regulates only the temperature of the mixed water. To close and adjust the water flow rate add a flow control between the mixture and the outlet.

PLUMBING RECOMMENDATIONS

- An independent hot and cold water supply is required for the shower system.
- The recommended pipe work should be 22mm minimum for low pressure system.
- If more than one shower mixer is installed, the minimum feed should be 28mm. (ensure adequate supply of both hot and cold water can be maintained)
- **READ CAREFULLY THIS MANUAL BEFORE USING YOUR MIXER AND KEEP IT AT HAND FOR FUTURE REQUIREMENTS**

INSTALLATION

ATTENTION: clean pipe work carefully prior to fitting the mixer

Consider the thickness of the final coating (tiles, marble etc.)

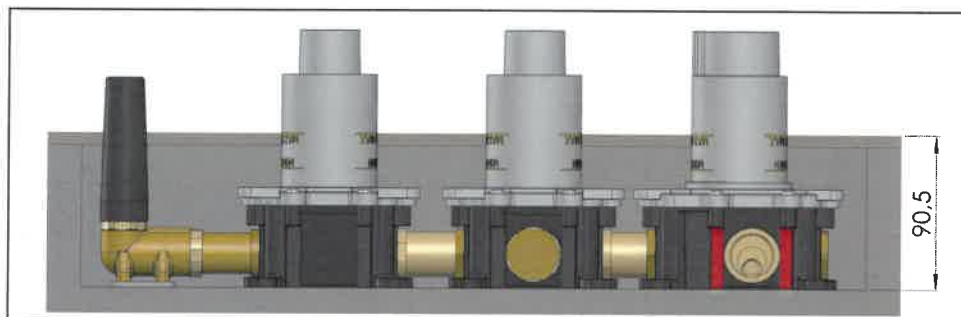
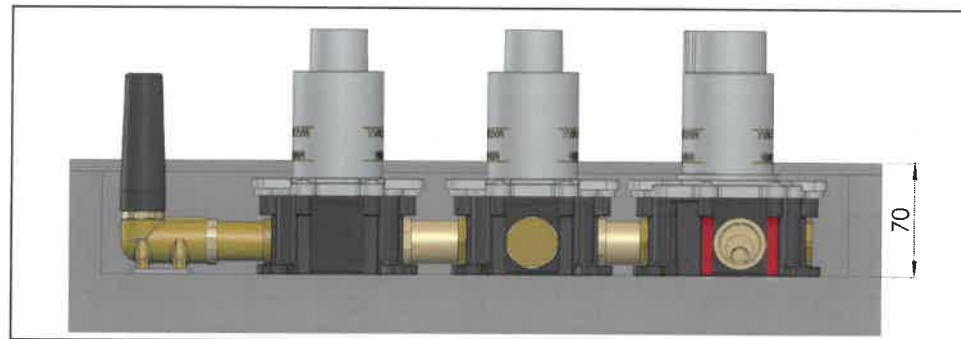

Keep a 56 mm hole in the wall to cut the protections and for the future maintenance of the product.

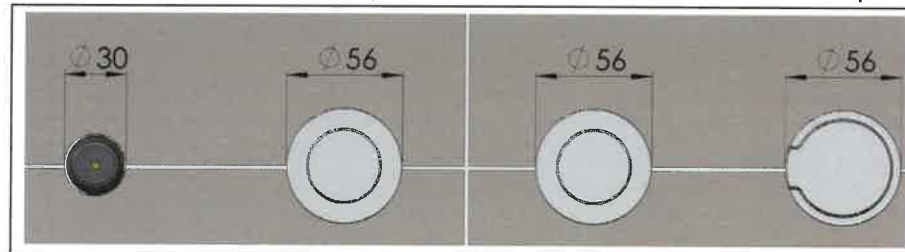

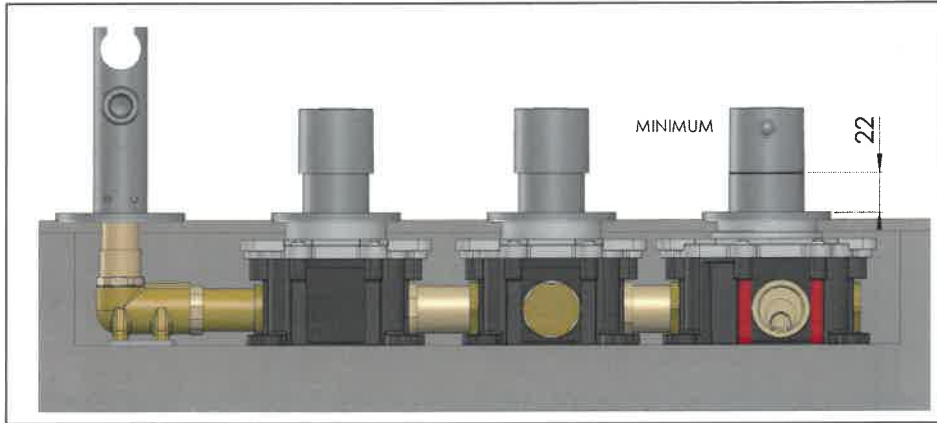

The plate slides from a minimum of 22 mm to a maximum of 1 mm.

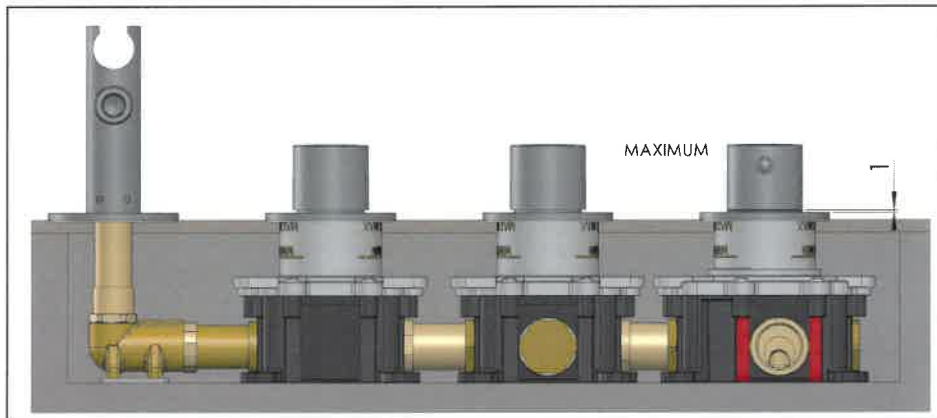

Before fixing the box, screw into the mixer ports the correct fittings for the type of tube chosen for your hydraulic system.
ATTENTION Fittings not supplied.

Use a level to find the correct position

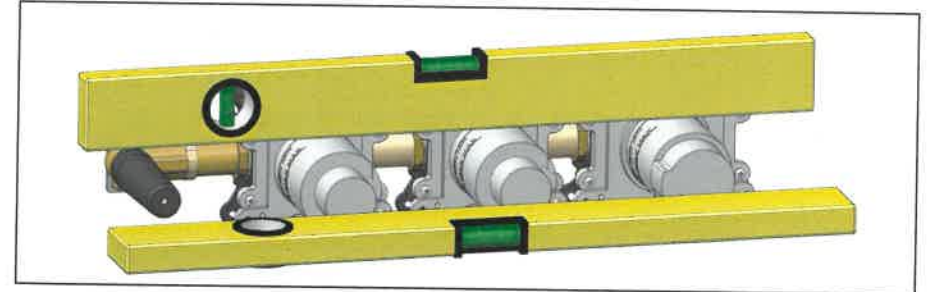

For the in-wall installation, drill the wall and use the plugs and screws to fix the box to the wall

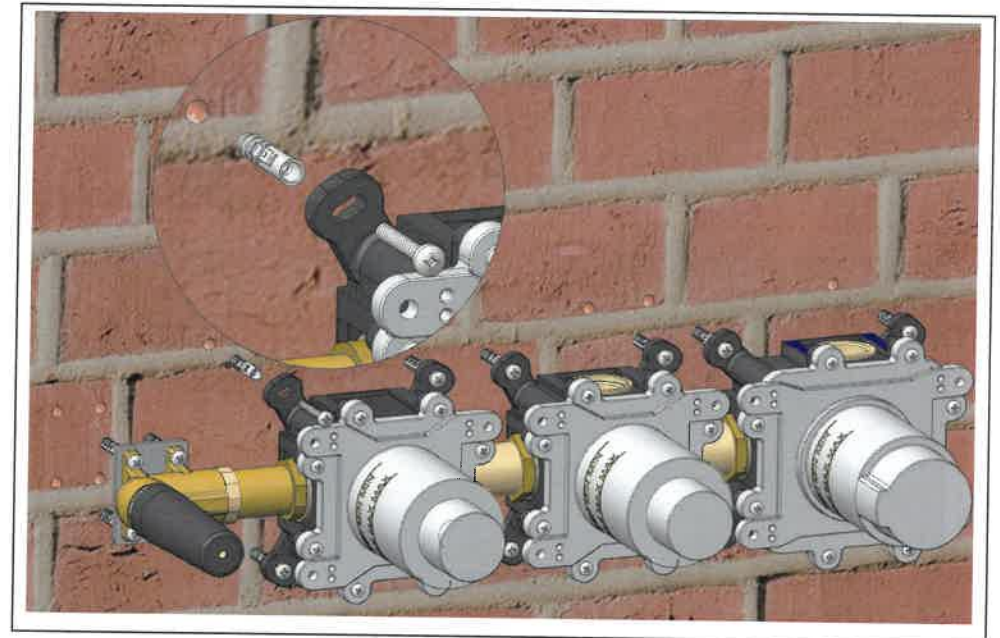

For the frame installation use the screws to fix the box to the woods.

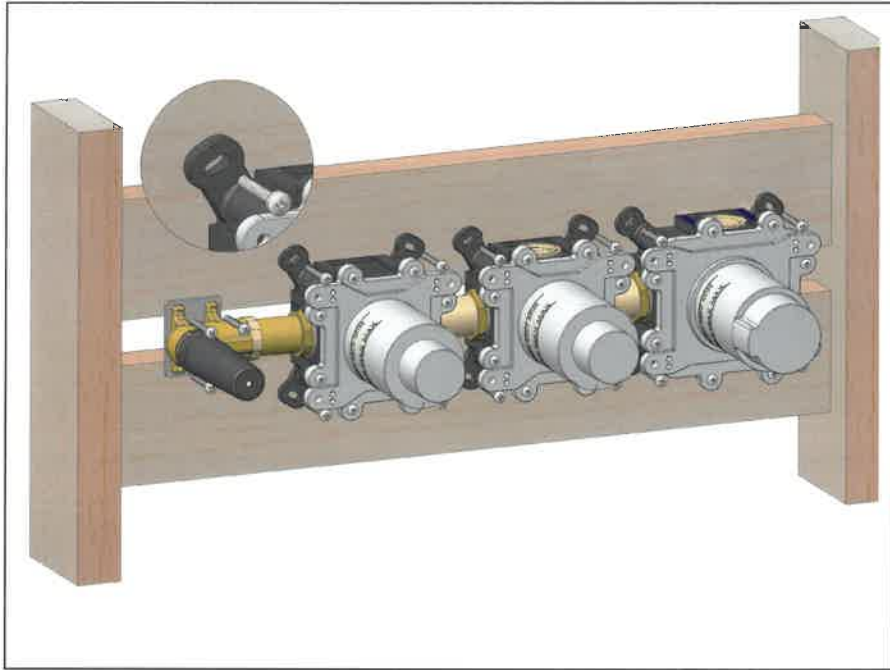

For the rear installation use the screw to fix the box to the drywall.

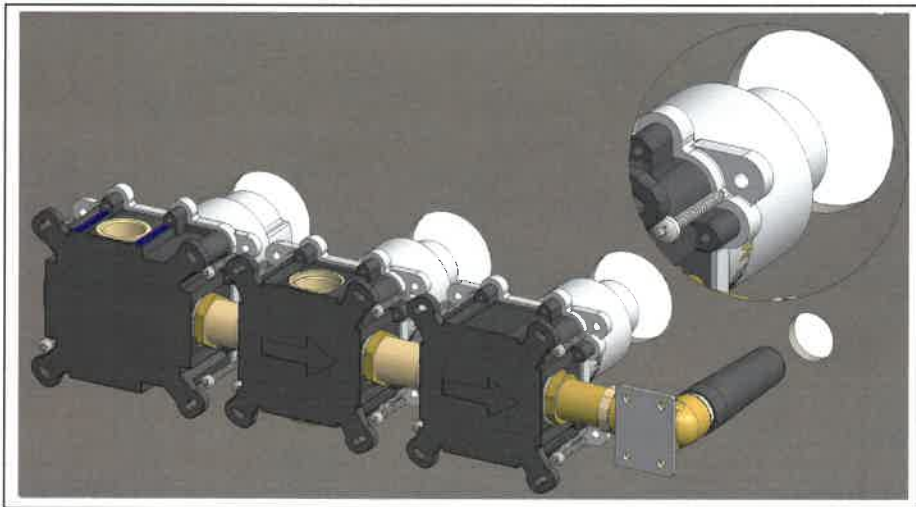

The box is made of plastic material

ATTENTION Never expose box to open flame or excessive heat.

In case of mixer ports NPT threaded, use fittings with a minimum length of 3".

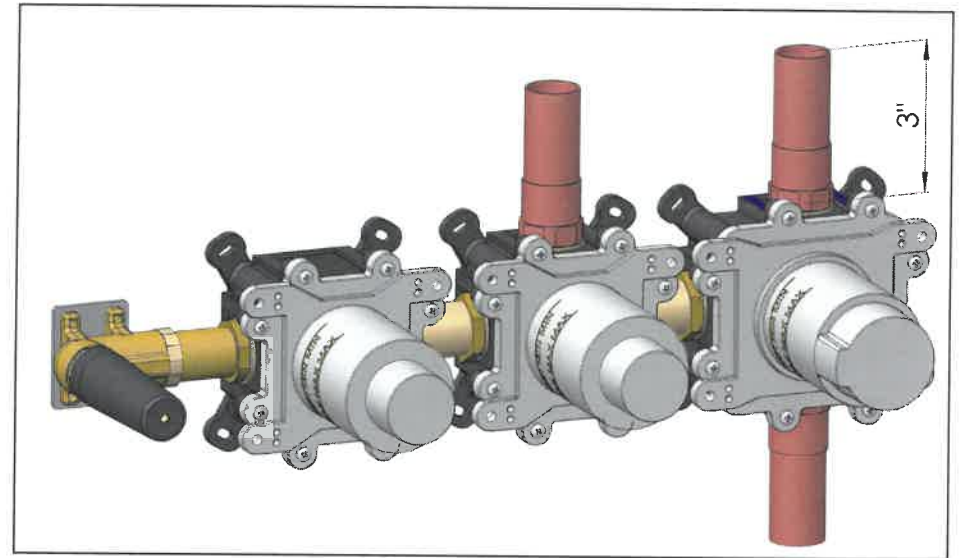

Before tiling attach the seal to the wall with glue.

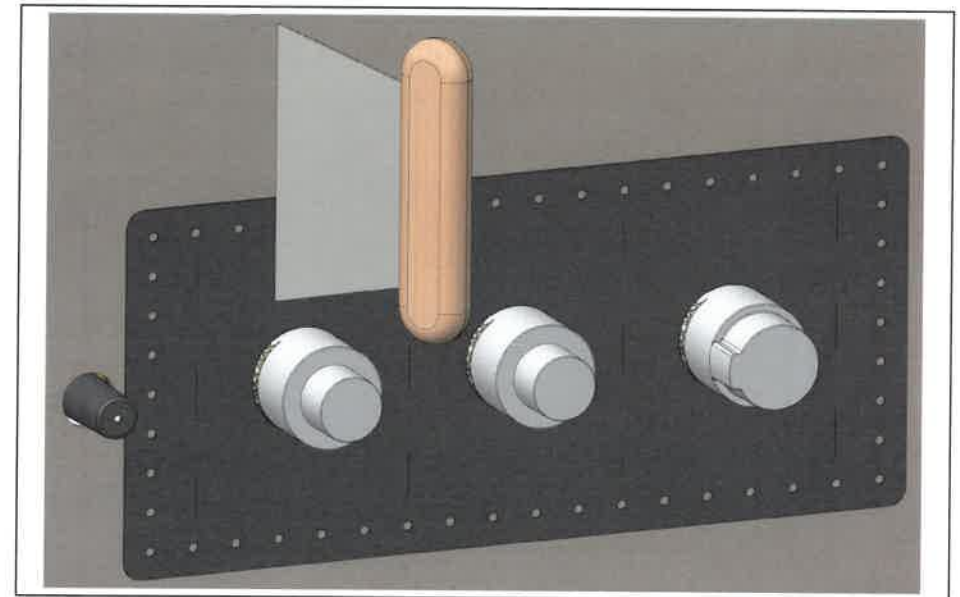

TRIM FIXING

Once the mixer is installed in the wall, cut along the finished wall and remove the plastic guard.

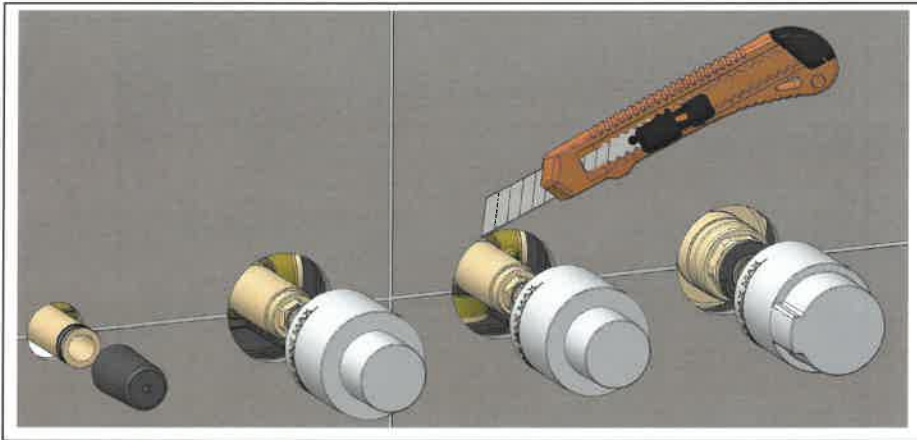

Put the silicone between the cover plate and the wall.

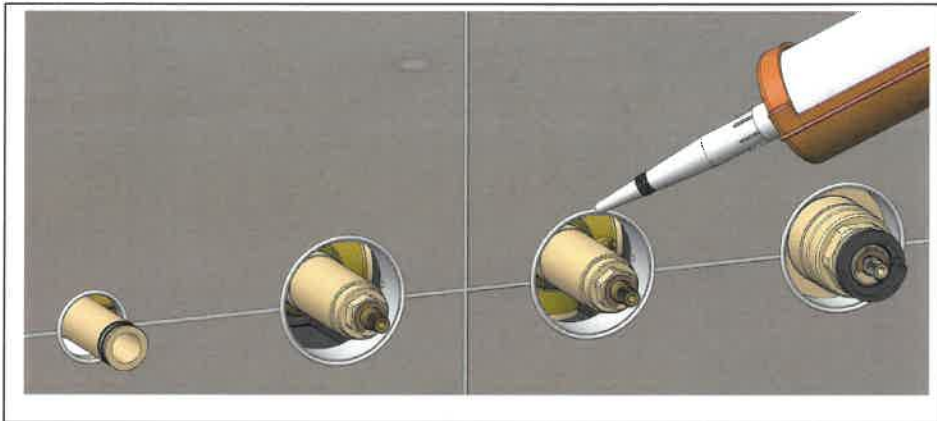

Fix the cover plate (1) on the threaded rod (2).

Screw the adapter (4) with their O-ring (3), until the plate (1) is against the wall.

Fix the insert (5) and fix the screw (6).

Position the handle (7) on the insert (5) and rotate until the vertical position is reached.

Screw the grub screw (8) with a 2,5 mm Allen key.

Screw the lever (9).

Fix the cover plate (10) on the chromed ring (11).

Fix the handle (12) screw the grub screw (13) with a 2,5 mm Allen key.

Fix the cap (14)

Fix the cover plate (15) on the extension (16)

Fix the support (19) with their O-ring (17), until the plate (15) is against the wall.

Screw the two grub screws (18) with a 2,5 mm Allen key



MAINTENANCE REPLACEMENT OF THE THERMOSTATIC CARTRIDGE AND VALVE HOLDER

REMOVE THERMOSTATIC CARTRIDGE

- 1) Remove the cup(1), Unscrew the grub screw (2) with an 2,5 mm Allen key
- 2) Remove the handle (3). Remove the plate (4).
- 3) Close the water inlets, in order to isolate the thermostatic cartridge.
- 4) Remove the stop ring(5).
- 5) Unscrew the thermostatic cartridge(6) anti-clockwise with a 30mm wrench.
- 6) Remove the thermostatic cartridge(6) and clean its filters under running water or leave to soak in vinegar in presence of limestone. **Grease the O-rings and, if damaged, replace them with new ones. 2x OR 2175 mm 44,17 x 1,78 1x OR 2187 mm 47,35 x 1,78**

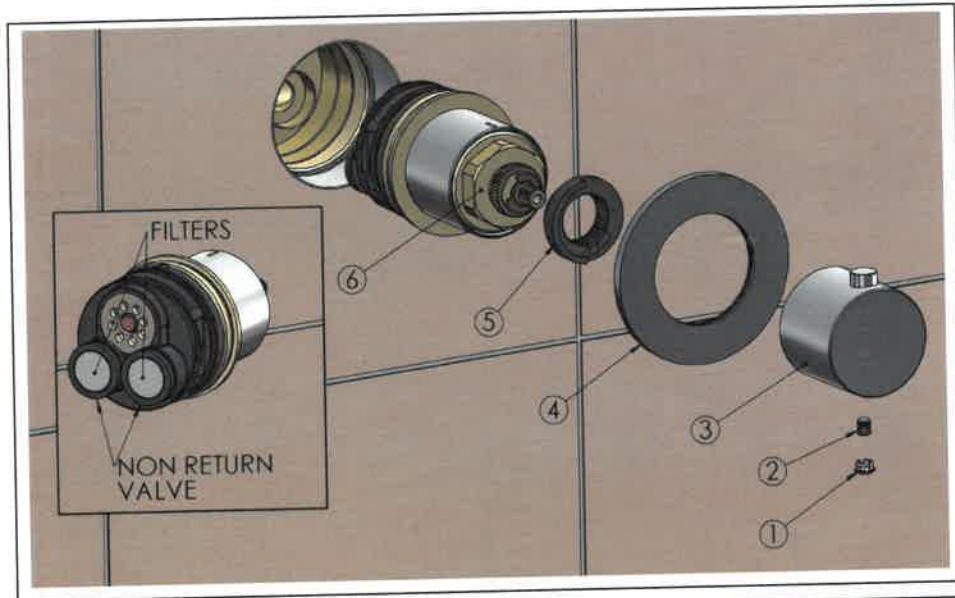

INSTALL THERMOSTATIC CARTRIDGE

1. Check that the reference on the body cartridge is upward

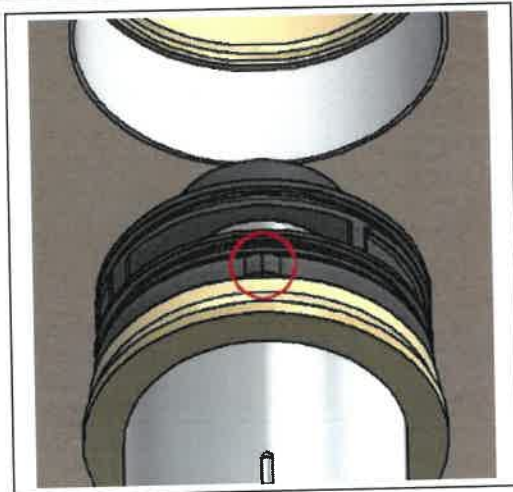

2. Match the reference on the body of the thermostatic cartridge with the reference in the mixer body

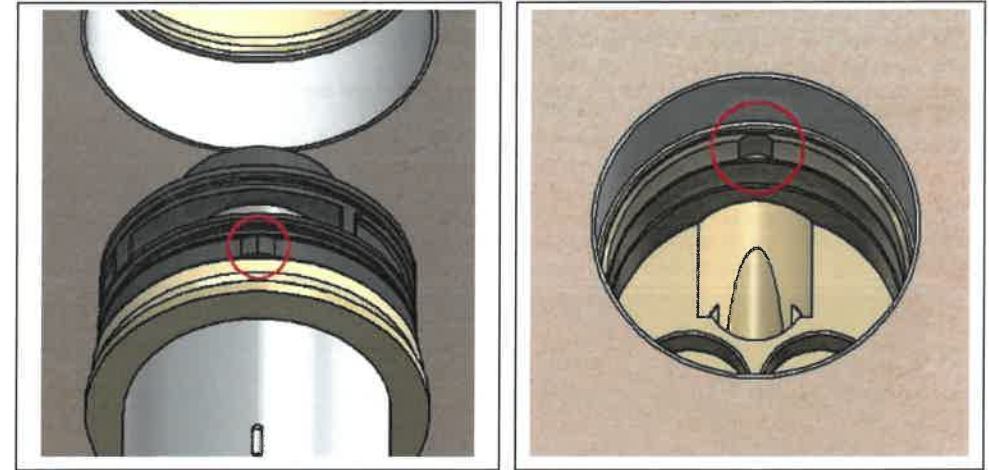

3. Screw the thermostatic cartridge(6) clockwise with a 30mm wrench.

POSITION OF THE STOP RING

- 1) Place the stop ring(5) as shown in the image below.
- 2) Using the handle, rotate the broached rod (A) to reach the set temperature of 38°C (check the temperature with a thermometer).

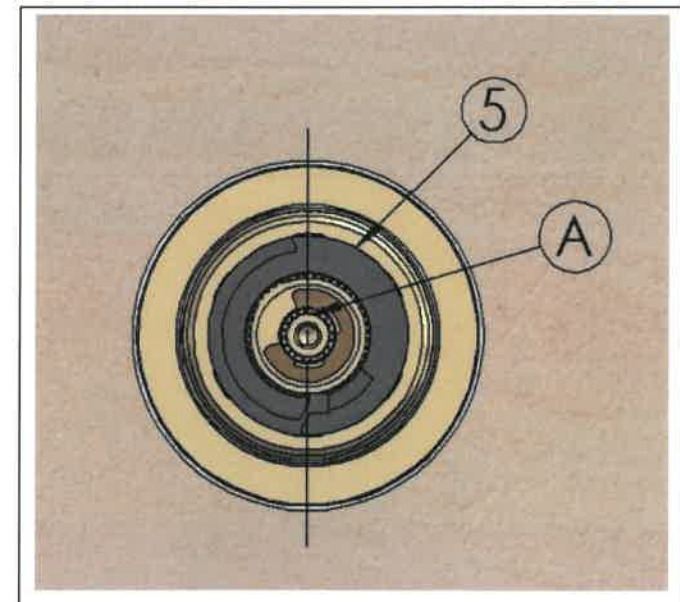

MAINTENANCE-REPLACEMENT OF THE SHUT OFF

- 1) Close the water inlets.
- 2) Remove the lever (1) and the grub screw (2) with 2,5 mm Allen key.
- 3) Remove the handle (3)
- 4) Unscrew the chromed adapter (4), being careful not to lose the O-ring (5).
- 5) Remove the cover plate (6).
- 6) Unscrew the threaded rod (7) with a 17 mm wrench.
- 7) Unscrew the headwork (8) with a 17 mm wrench.
- 8) Before replacing the headwork, clean thoroughly and grease the inner seat of the body.
- 9) Replace the headwork (8) and screw the threaded rod (7).
- 10) Assemble the trim following the instructions of TRIM FIXING.

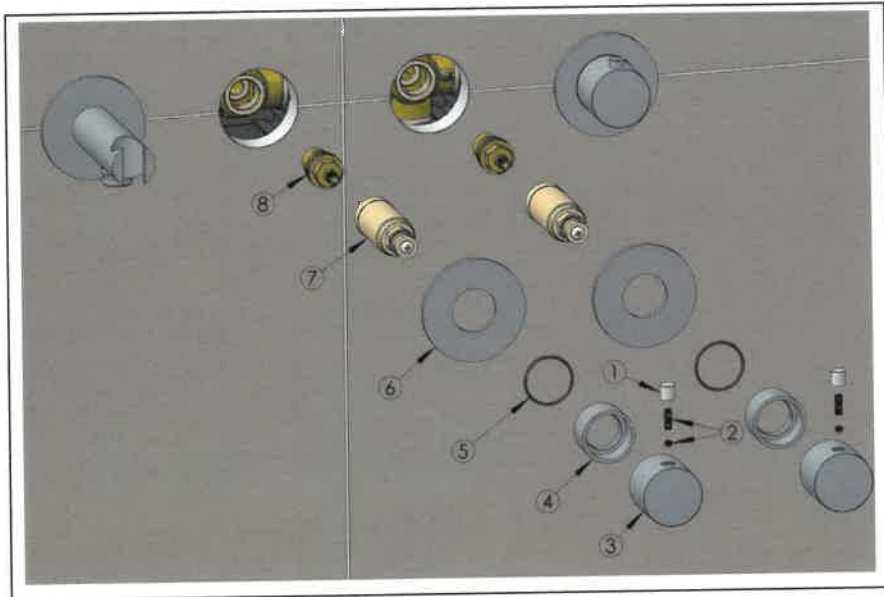

IMPORTANT-CLEANING OF THE MIXER

After use the mixer should be maintained by wiping with a soft, damp, clean cloth. NO abrasive powders, detergents or polishes, cleaners containing alcohol, acid or corrosive chemicals should be used.

In case of prolonged disuse of the mixer in winter time, it is recommended to close the system and empty the mixer to avoid damages caused by frost.

NOTES

- If these simple instructions are followed this mixer will give many years of satisfactory use.
- The company has policy of continuous improvement and reserve the right to change specification without notice.

GUARANTEE

The mixer is guaranteed for a period of 5 years against any defect of material and workmanship from date of the purchase, subject to correct installation, maintenance and use in accordance with this instruction leaflet.

Please retain proof of purchase. During the guarantee period parts will be replaced or repaired at our option.

TROUBLE SHOOTING

| Problem | Cause | Solution |
|-----------------------------------------------------------------------------------------------------------------------|------------------------------------------------------------------------------------------------------------------------------------------------------------------------------------------------------------------------------------------|----------------------------------------------------------------------------------------------------------------------------------------------------------------------------------------------------------------------------------------------------------------------------------------------------------------------------|
| 1. Reduced or missing flow | <p>a) Closed water inlets.</p> <p>b) Blocked mixer.</p> <p>c) Blocked connecting pipes.</p> <p>d) Blocked hand shower.</p> <p>e) Water flow reduction when other shut off valves are in function.</p> | <p>a) Control the check valves.</p> <p>b) Check if the inlet filters are cleaned.</p> <p>c) Check if the connecting pipes are cleaned.</p> <p>d) Clean or replace the hand shower.</p> <p>e) Control if the check valves are fully open. Reduce the water flow of all open outlets.</p> |
| 2. The mixer does not shut off. | <p>a) The gaskets are dirty.</p> <p>b) The gaskets are damaged.</p> | <p>a) Clean/replace the gaskets.</p> <p>b) Replace the headwork.</p> |
| 3. Water too cold. | <p>a) There is not enough hot water flowing through the mixer.</p> <p>b) The boiler system does not give enough hot water.</p> <p>c) The hot water inlet is restricted.</p> | <p>a) Set the regulation handle towards the hot water side.</p> <p>b) Increase the temperature of the water fed from the boiler.</p> <p>c) Check for any restriction on the pipeline.</p> |
| 4. Water too hot. | <p>a) There is not enough cold water flowing through the mixer.</p> <p>b) The cold water inlet is restricted.</p> | <p>a) Set the regulation handle towards the cold water side.</p> <p>b) Check for any restriction on the pipeline.</p> |
| 5. Temperature varies during use. | <p>a) Temperature has decreased below the minimum required.</p> | <p>a) Wait for the hot water to be restored.</p> |
| 6. Fluctuation of temperature of the mixer water | <p>a) Inverted connections.</p> <p>b) Inverted mixer.</p> | <p>a) Invert the mixer</p> |
| 7. Increasing of the temperature by turning clockwise. Decreasing of the temperature by turning anti-clockwise | <p>a) Inverted connections.</p> <p>b) Inverted mixer.</p> | <p>a) Invert the mixer.</p> |

